

KIT 5530

85553000200

**Revell**

# HEINKEL He 111H-22

In one of its very last roles the Heinkel He 111H-22 provided a moving launch platform for the V-1 Flying Bomb. With internal bomb and fuel storage removed, Heinkel pilots would fly low level sorties over England and release their flying bombs. The Flying Bombs were so secret not even the Heinkel crews could see them as they were covered until take-off.

Your Revell model features a special wing attachment pylon and Fieseler Fi missile (V-1 Buzz Bomb), three crew figures, detailed cockpit, landing gear and authentic WWII decals.



\* REPEAT SEVERAL TIMES \* REPEAT PROCEDURE \* OPTIONAL PARTS \* DECAL \* ASSEMBLY CAUTION \* CEMENT TOGETHER \* REMOVE AND THROW AWAY \* DO NOT CEMENT  
 \* A REPETER PLUSIEURS FOIS \* RÈPÈTEZ LE PROCÉDÉ \* PIÈCES EN OPTION \* DECAL COMANIE \* ATTENTION D'ASSEMBLÉE \* A COLLER \* A RETIRER ET JETER \* NE PAS COLLER

**READ THIS BEFORE YOU BEGIN**

- \* Study the assembly drawings.
- \* Each plastic part is identified by a number.
- \* In the assembly drawings, some parts will be marked by a star (★) to indicate chrome plated plastic.
- \* For better paint and decal adhesion, wash the plastic parts in a mild detergent solution. Rinse and let air dry.
- \* Check the fit of each piece before cementing in place.
- \* Use only cement for polystyrene plastic.
- \* Scrape plating and paint from areas to be cemented.
- \* Allow paint to dry thoroughly before handling parts.
- \* Any unused parts may be discarded.

**DECAL APPLICATION INSTRUCTIONS**

1. Cut desired decal from sheet.
2. Dip decal in water for a few seconds.
3. Place wet decal on paper towel.
4. Wait until decal is movable on paper backing.
5. Place decal in position on model, face up and slide backing away.
6. Press out air bubbles with a soft damp cloth.
7. Milkyness that may appear is for better decal adhesion and will dry clear. Wipe away any excess adhesive.
8. Do not touch decal until fully dry.
9. Allow the decals 48 hours to dry before applying clear coat.

**NOTE:** Decals are compatible with setting solutions or solvents.

**LIRE CE QUI SUIT AVANT DE COMMENCER**

- \* Etudier les schémas de montage.
- \* Chaque pièce en plastique est identifiée par un numéro.
- \* Sur les schémas de montage, certaines pièces sont marquées d'une étoile (★) pour indiquer qu'elles sont en plastique chromé.
- \* Pour une meilleure prise de la peinture et des autocollants, laver les pièces en plastique avec une solution détergente peu concentrée. Les rincer et les laisser sécher à l'air.
- \* Vérifier que chaque pièce s'ajuste bien avant de la coller en place.
- \* N'utiliser que de la colle pour polystyrène.
- \* Gratter les parties à coller pour enlever le chrome et la peinture.
- \* Laisser la peinture bien sécher avant de manipuler les pièces.
- \* Toute pièce inutilisée peut être jetée.

**DIRECTIVES D'APPLICATION DES AUTOCOLLANTS**

1. Découper l'autocollant désiré de la feuille.
2. Tremper l'autocollant dans de l'eau pendant quelques secondes.
3. Placer l'autocollant mouillé sur une serviette en papier.
4. Attendez que l'autocollant puisse être déplacé sur son support en papier.
5. Mettre l'autocollant en position sur le modèle face sur le dessus et faire glisser le support pour l'enlever.
6. Appuyer avec un chiffon doux humide pour éliminer les bulles d'air.
7. La substance laiteuse qui peut apparaître est destinée à améliorer l'adhésion de l'autocollant et devient incolore au séchage. Essuyer pour enlever tout excédent d'adhésif.
8. Ne pas toucher l'autocollant tant qu'il n'est pas bien sec.
9. Laisser l'autocollant sécher pendant 48 heures avant d'appliquer une couche transparente.

**REMARQUE:** Les autocollants sont compatibles avec les solutions de fixation ou les solvants.

*This paint guide is provided to complete this kit as shown on the box.*

*Ce guide de peintures est fourni pour reproduire le modèle réduit qui apparaît sur la boîte.*

Semi Gloss Black	Noir satiné
Gunmetal	Bronze
Dark Black Gray	Noir gris foncé
Dark Gray	Gris foncé
Light Gray	Gris clair
White	Blanc
Olive Green	Gris vert
Dark Green	Vert foncé
Black Green	Vert noir
Light Blue Gray	Bleu gris clair
Silver	Argent
Steel	Acier
Red	Rouge

If you have any questions or comments, call our hotline at: **(800) 833-3570**  
 or, please write to:

**Revell Inc Consumer Service Department, 1850 Howard Street Unit A, Elk Grove Village, Illinois 60007**

Be sure to include the plan number (85553000200), part number, description, your return address and phone number.

Visit our website: [www.revell.com](http://www.revell.com)

# 1

## FIGURE ASSEMBLY

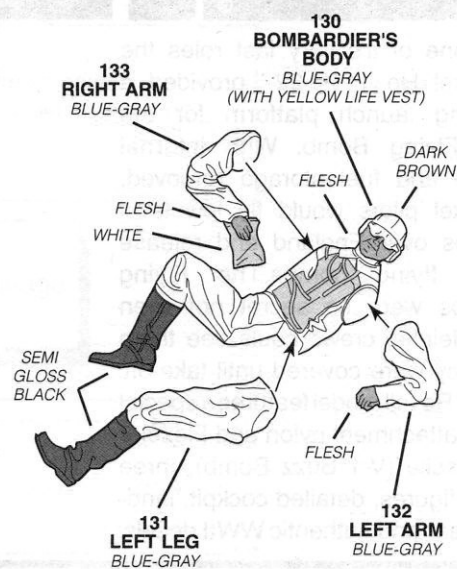
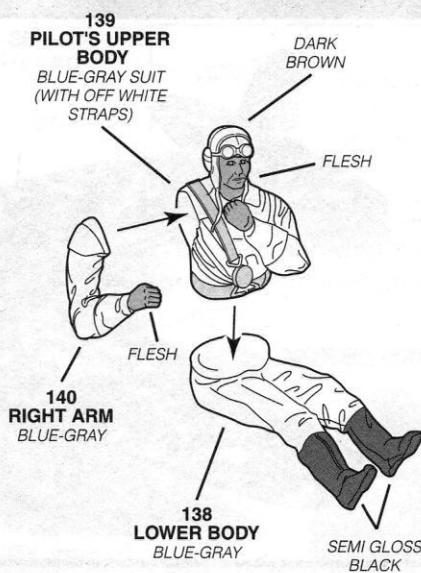
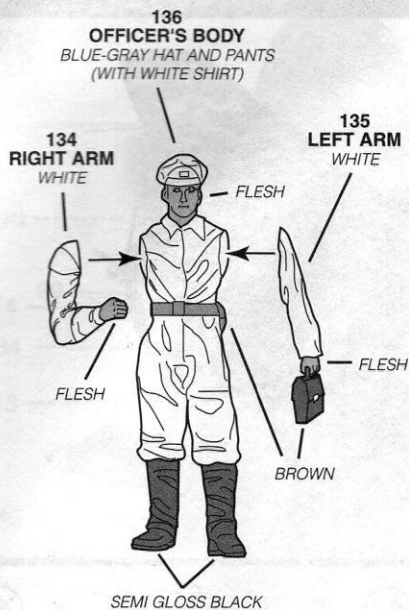

# 2

## COCKPIT ASSEMBLY

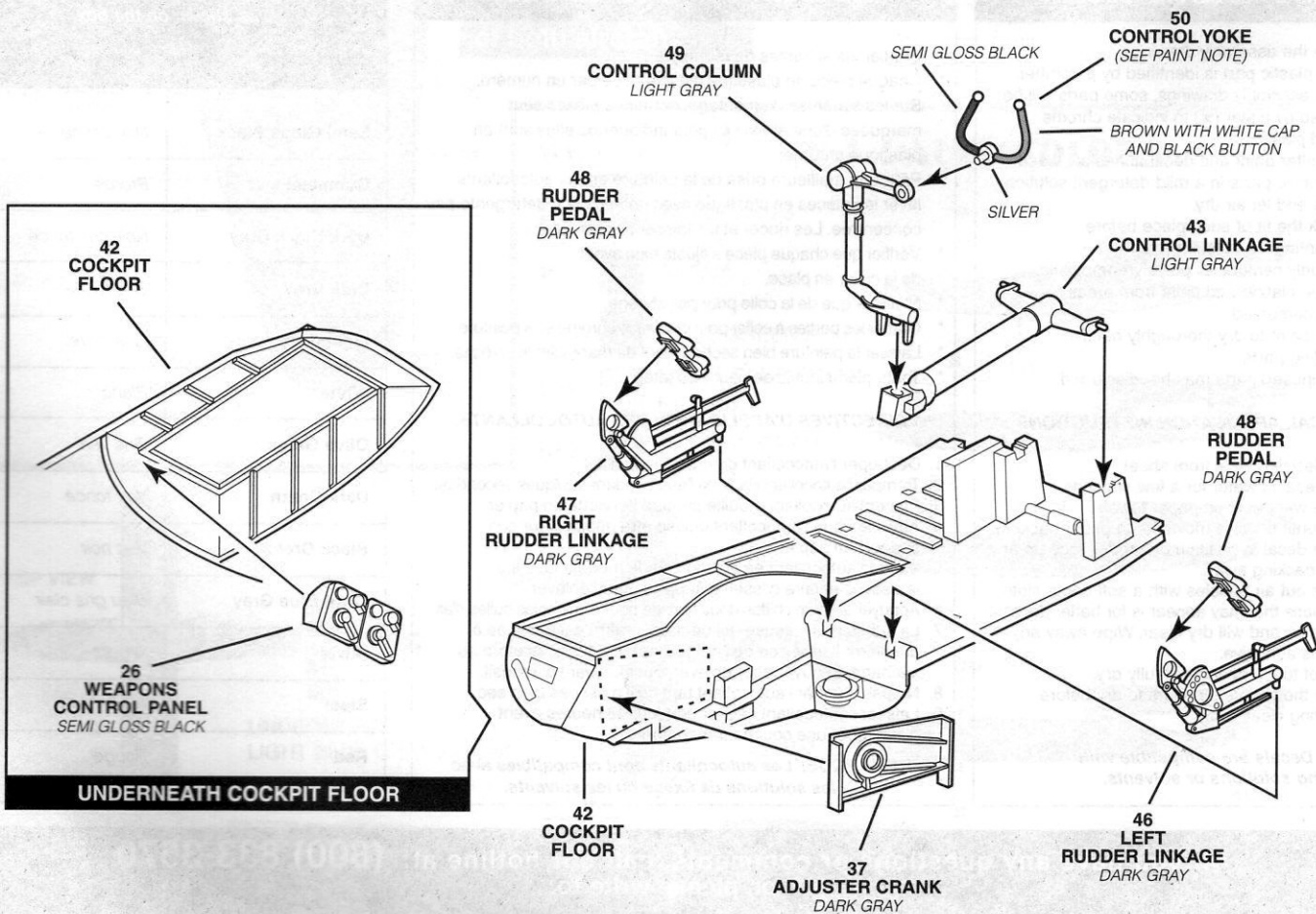

# 2

## COCKPIT ASSEMBLY CONTINUED

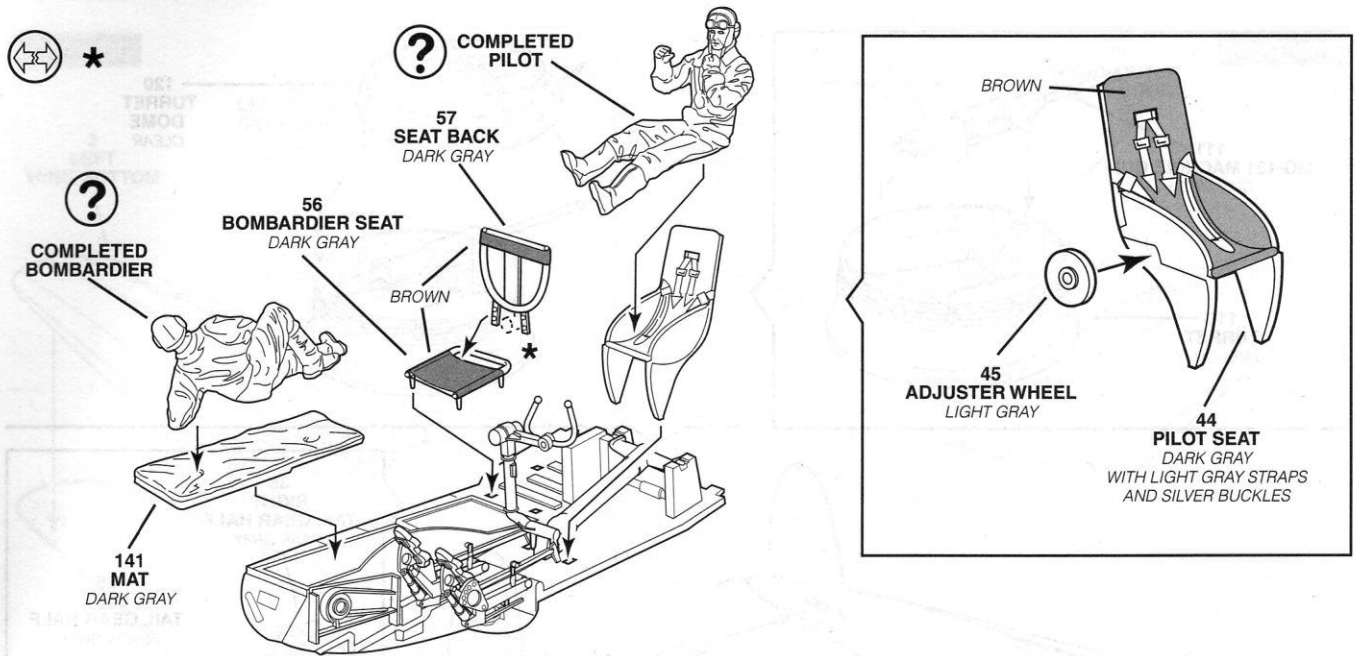

# 3

## FUSELAGE ASSEMBLY

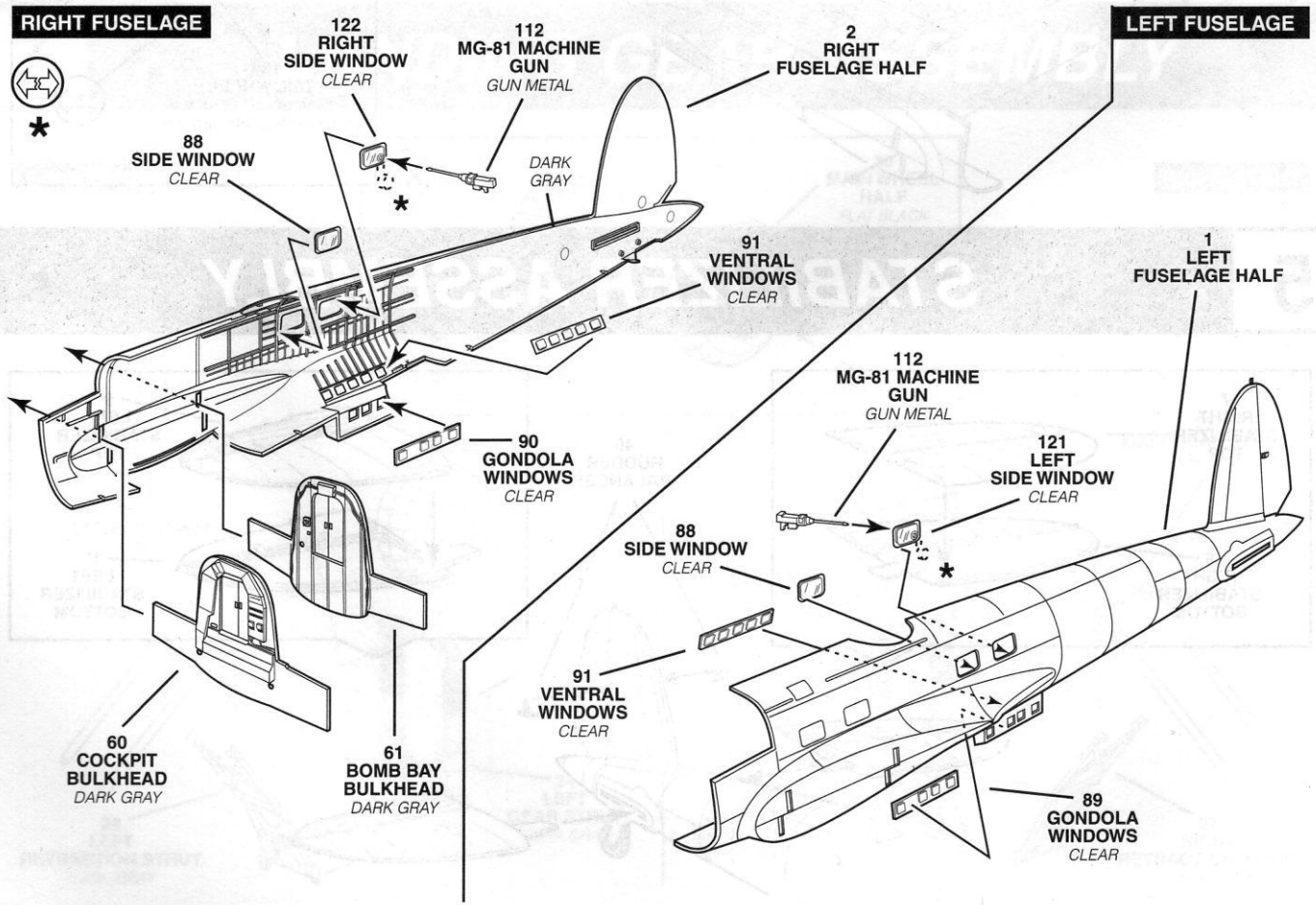

# 4

# TURRET / FUSELAGE ASSEMBLY

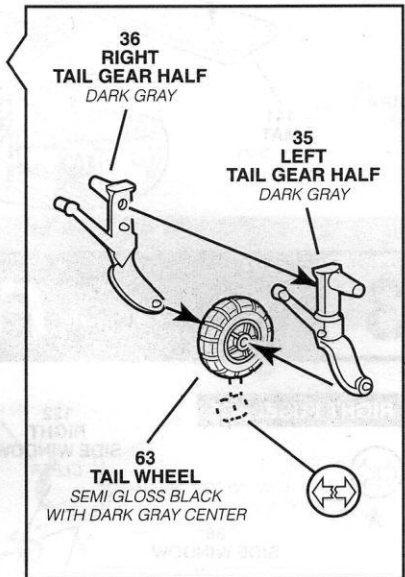
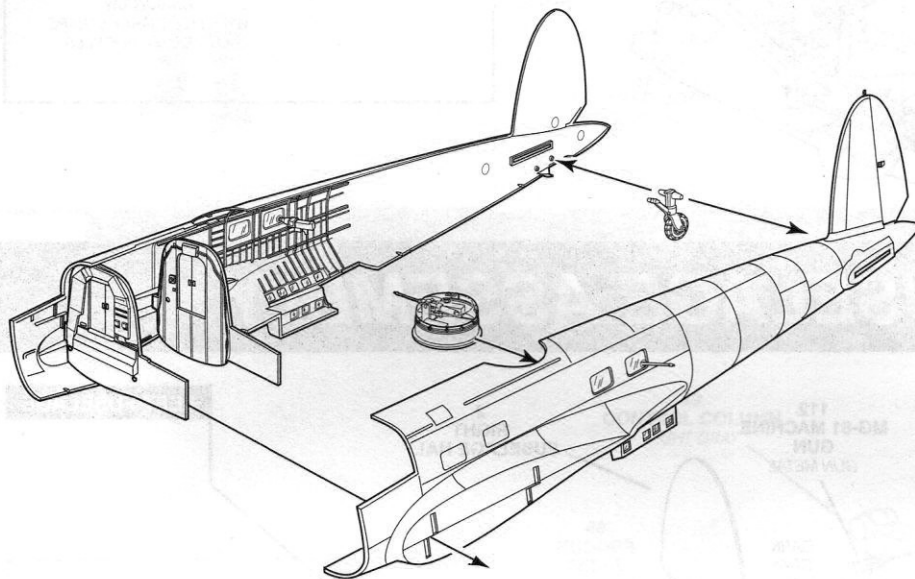
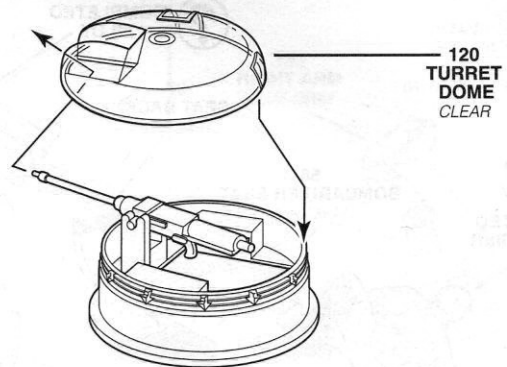
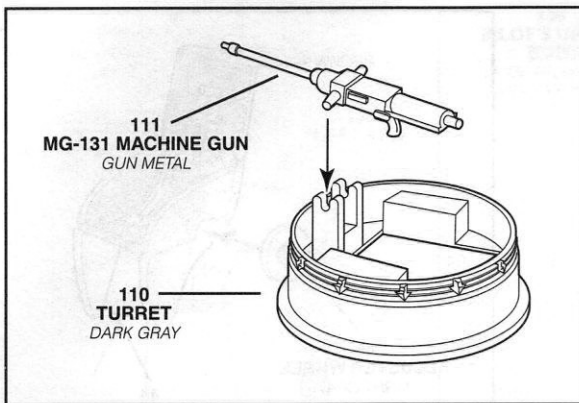

# 5

# STABILIZER ASSEMBLY

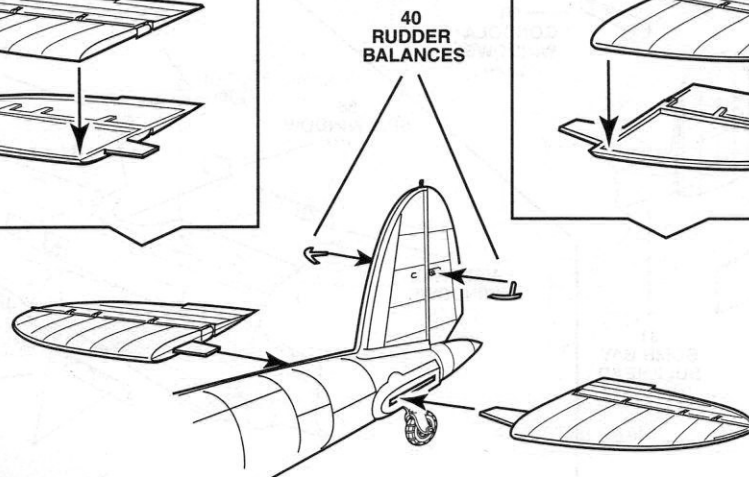
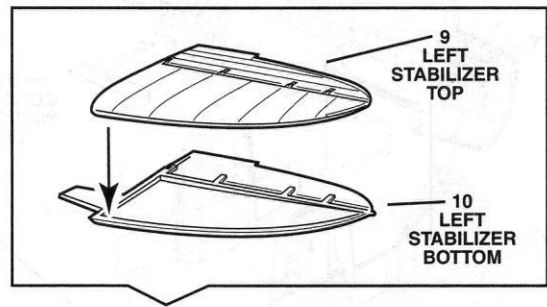
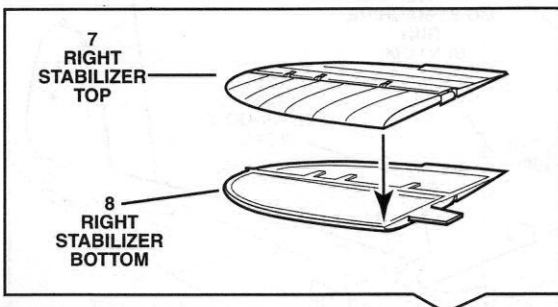

# 6

# WING ASSEMBLY

## LEFT WING

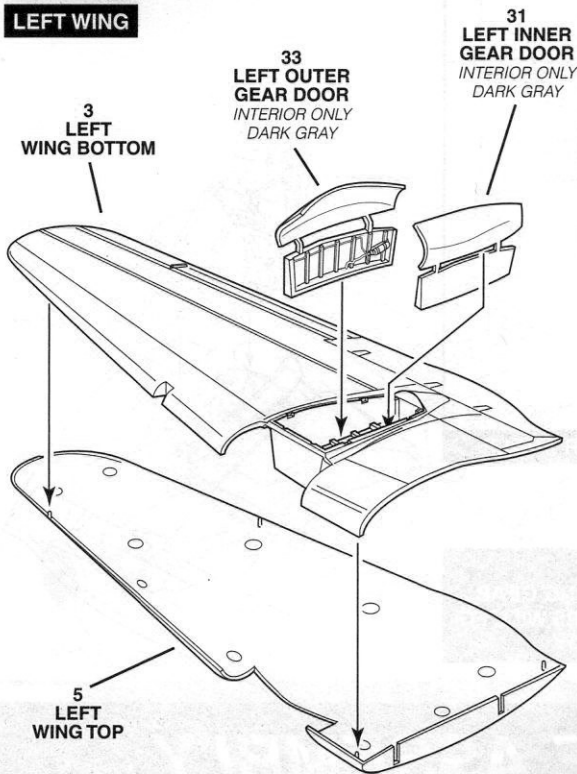

## RIGHT WING

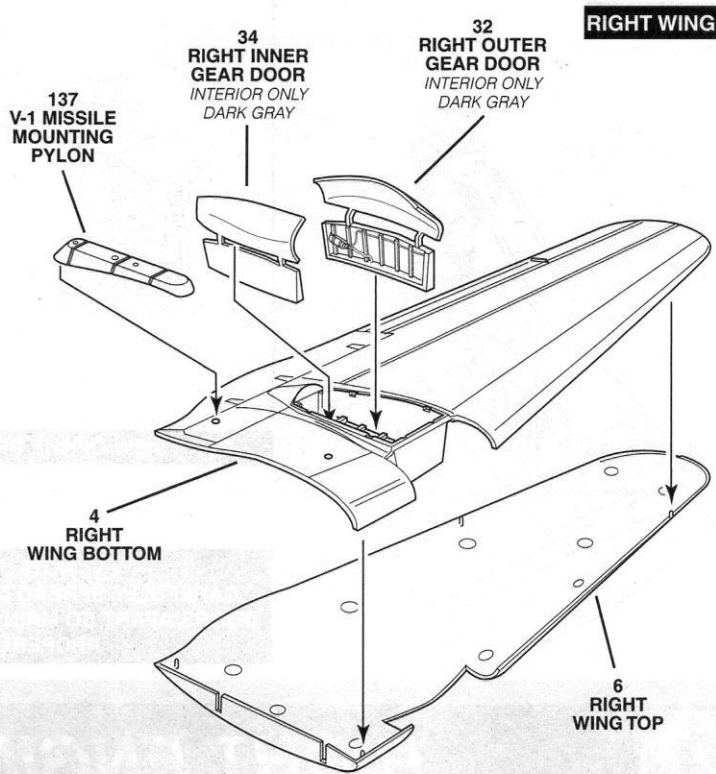

# 7

# LANDING GEAR ASSEMBLY

## LEFT STRUT

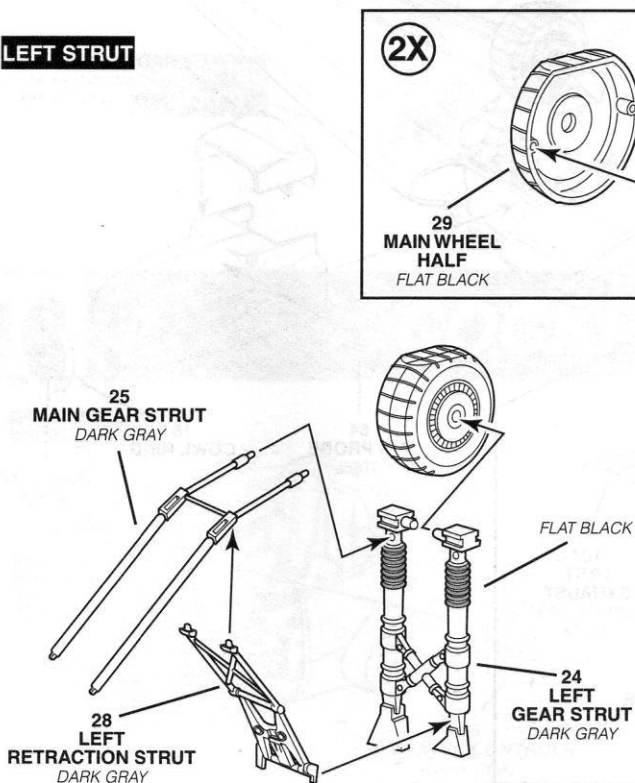

## RIGHT STRUT

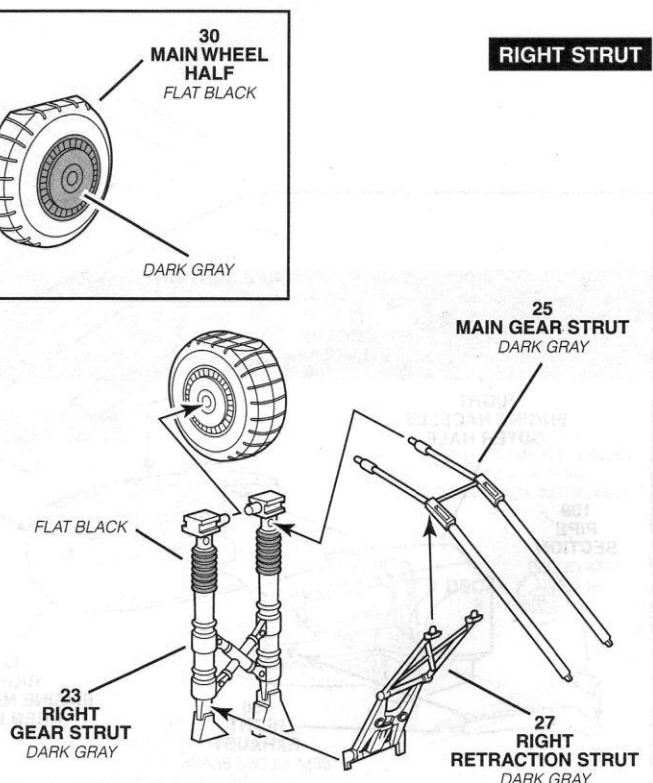

# 8

## STRUTS TO WING ASSEMBLY

LEFT

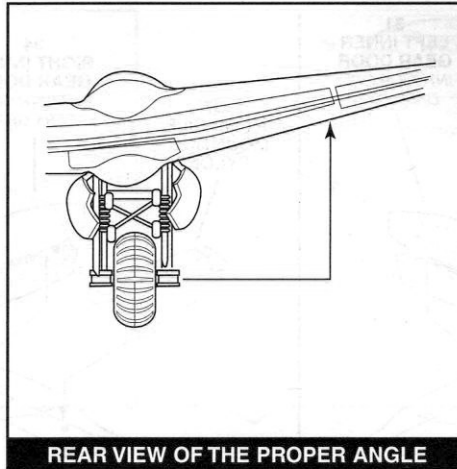
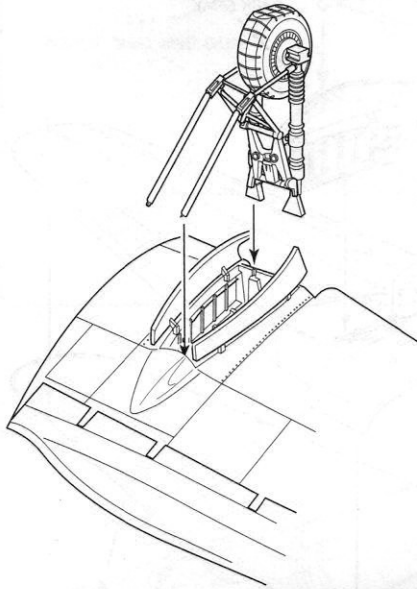

REAR VIEW OF THE PROPER ANGLE

RIGHT

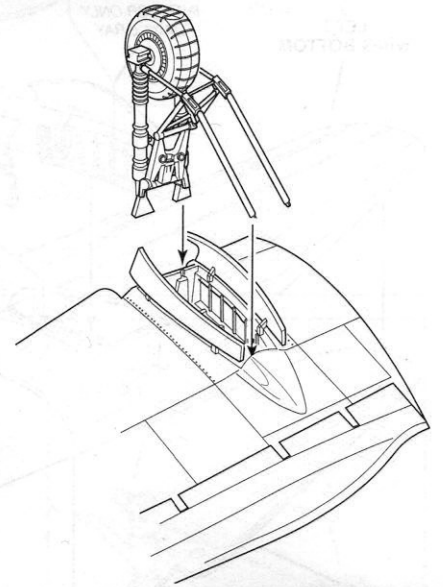

**NOTE:**  
CAREFULLY SPREAD LANDING GEAR DOORS APART SO MAIN GEARS WILL FIT PROPERLY.

# 9

## RIGHT ENGINE ASSEMBLY

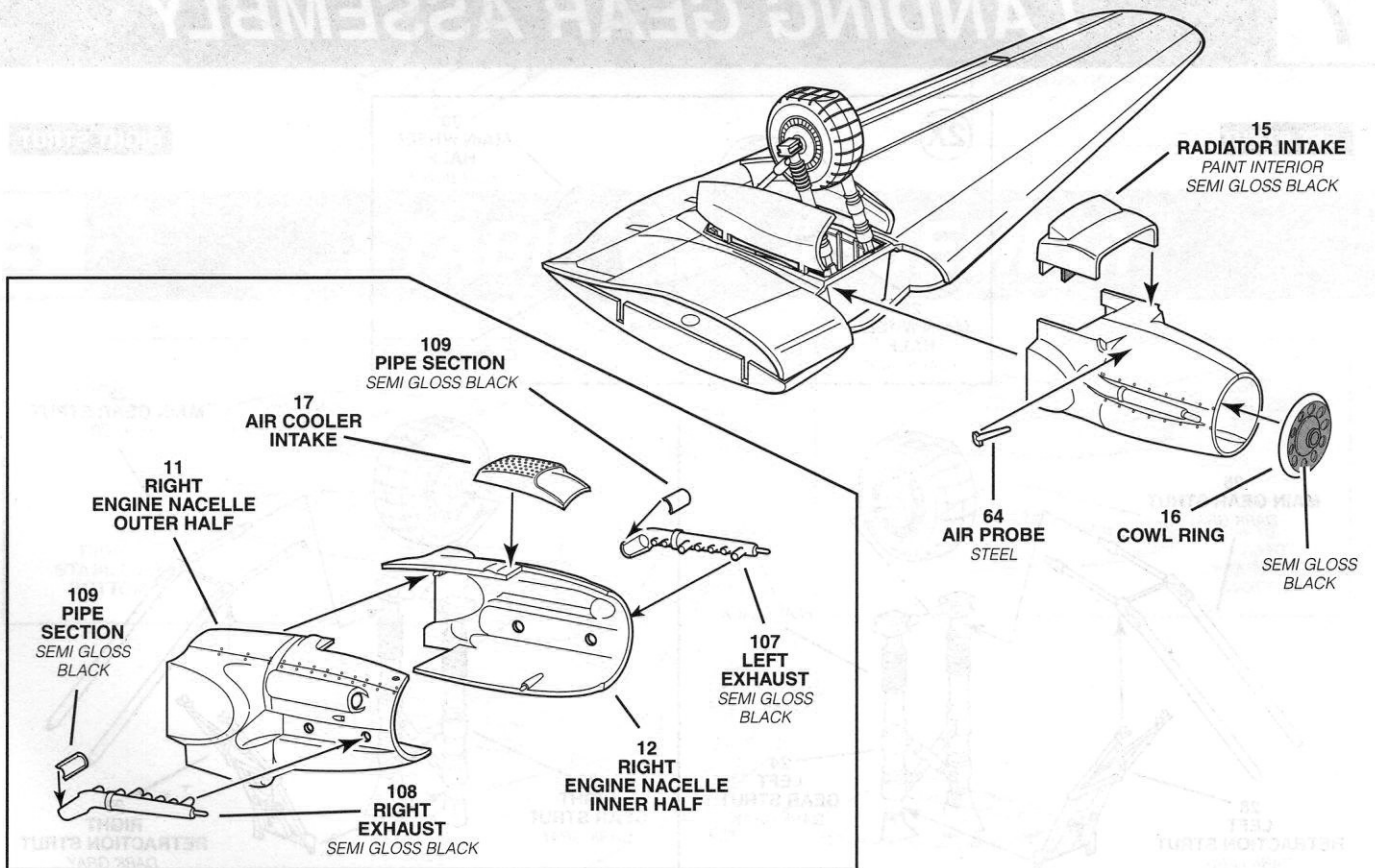

# 13

# GONDOLA ASSEMBLY

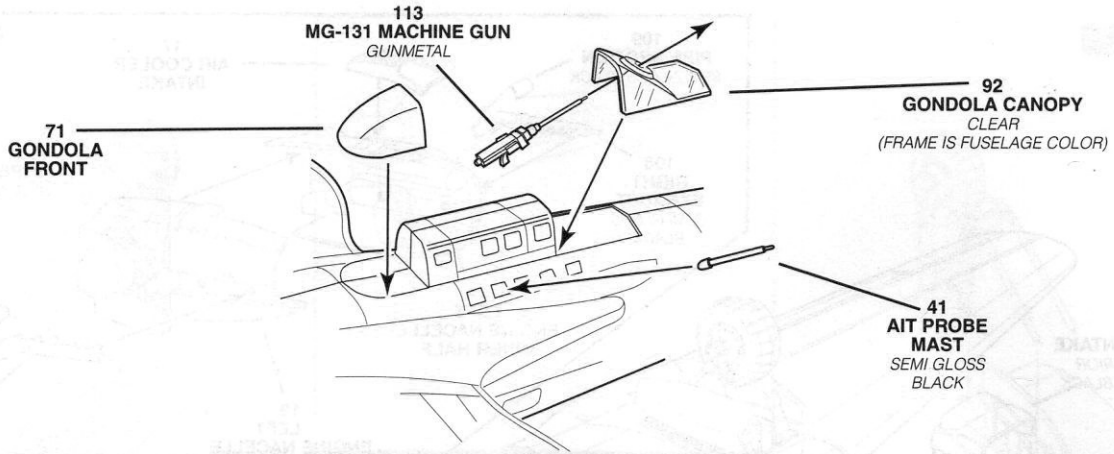

# 14

# V-1 MISSILE / BOMB DOOR ASSEMBLY

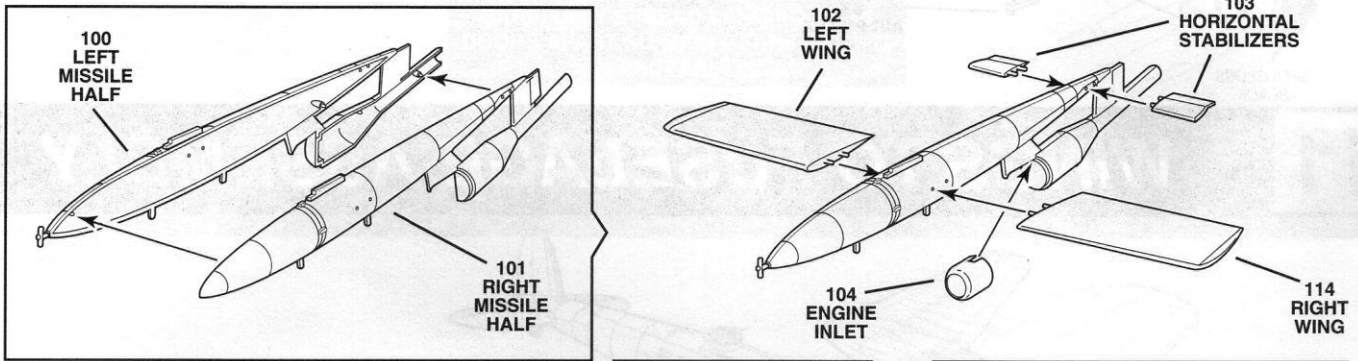

39 BOMB BAY DOORS  
PAINT EXTERIOR THE SAME COLOR  
AS THE UNDERSIDE OF THE AIR-  
CRAFT

PAINT DARK GRAY  
(INSIDE)

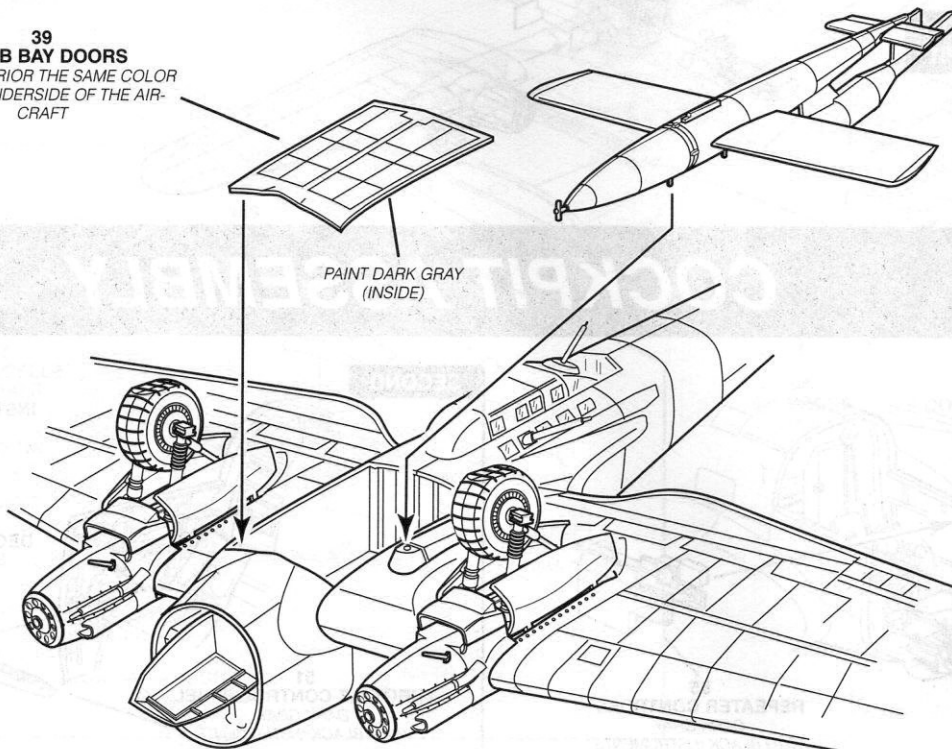

# 13

## GONDOLA ASSEMBLY

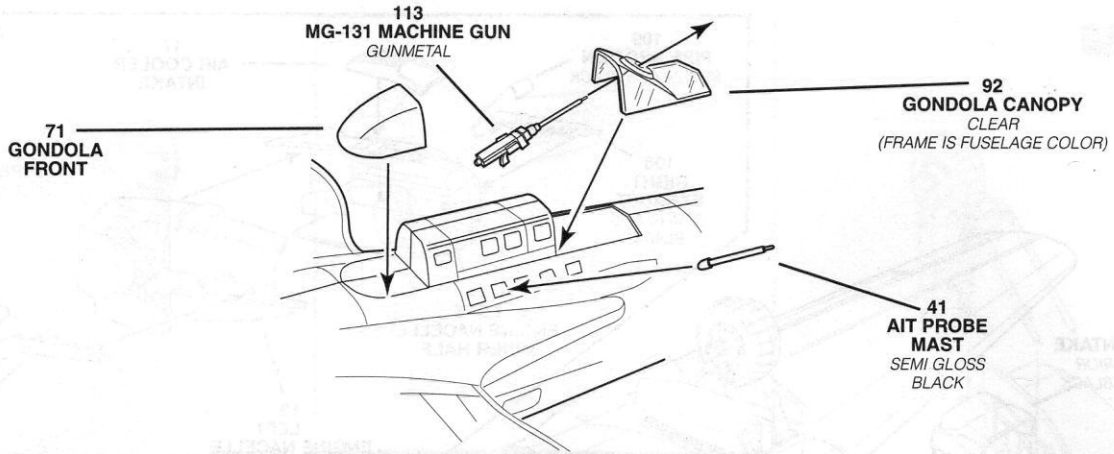

# 14

## V-1 MISSILE / BOMB DOOR ASSEMBLY

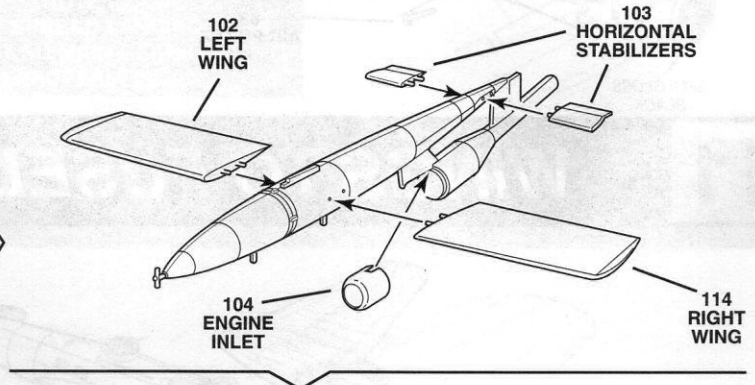
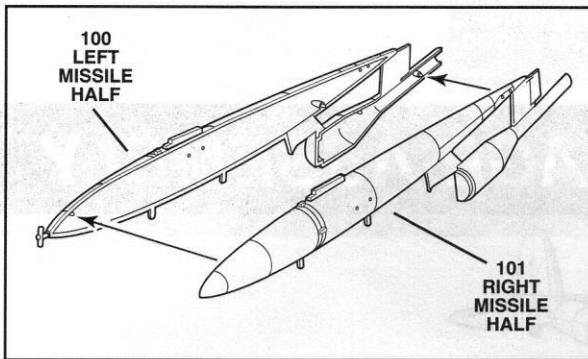

39 BOMB BAY DOORS  
PAINT EXTERIOR THE SAME COLOR  
AS THE UNDERSIDE OF THE AIR-  
CRAFT

PAINT DARK GRAY  
(INSIDE)

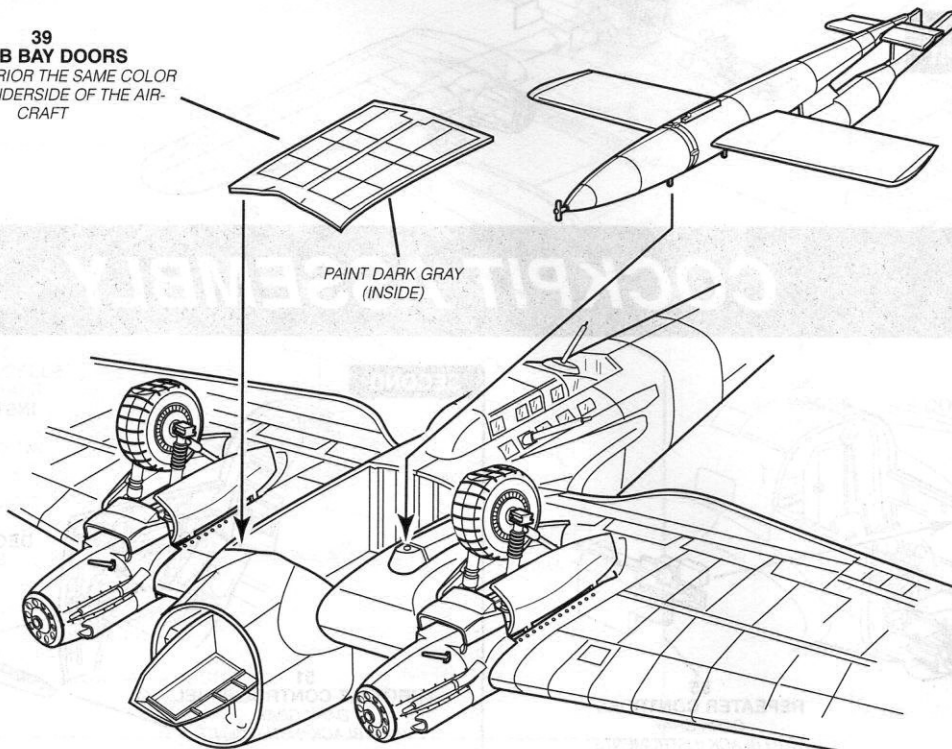



# 15

# CANOPY ASSEMBLY

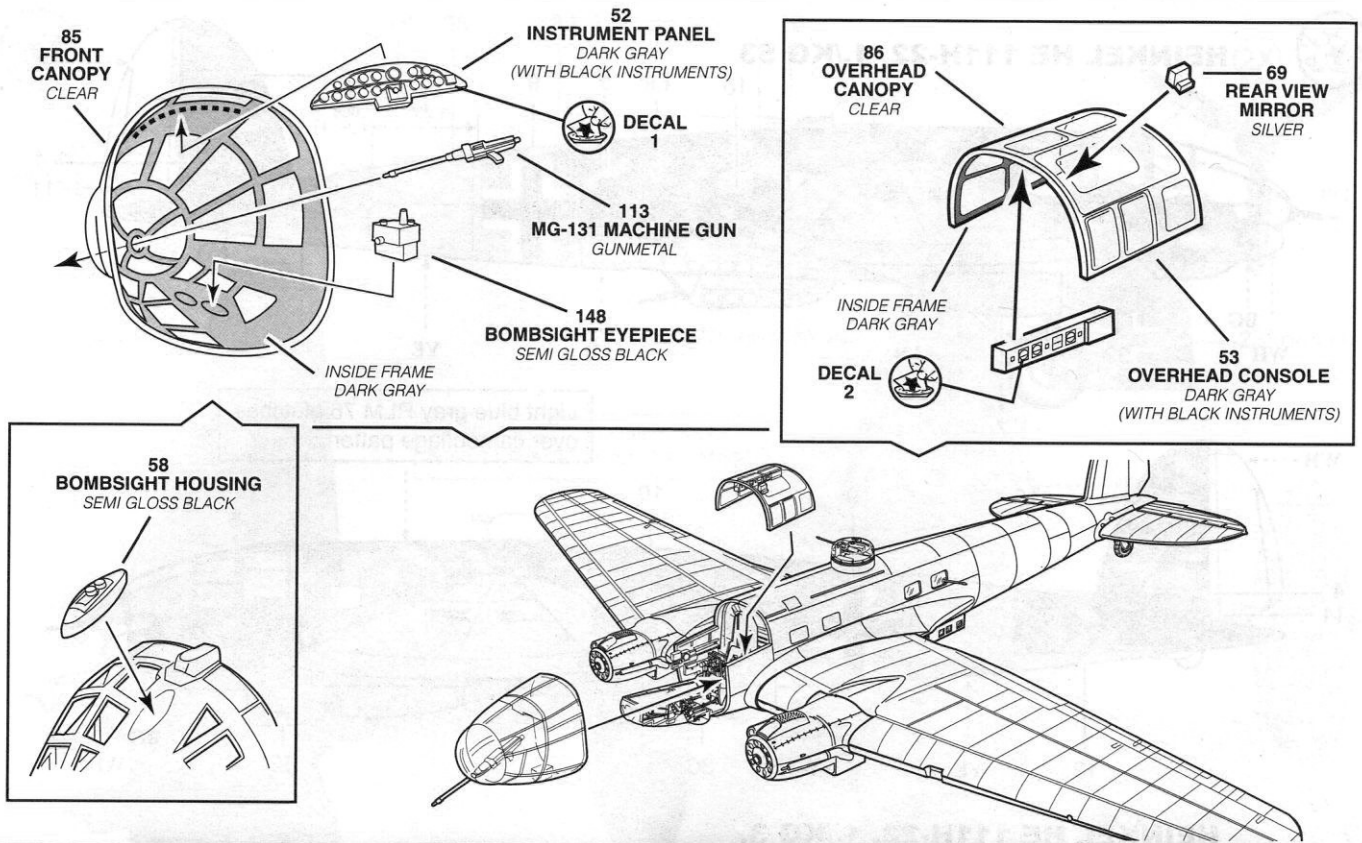

# 16

# PROPELLER / FINAL ASSEMBLY

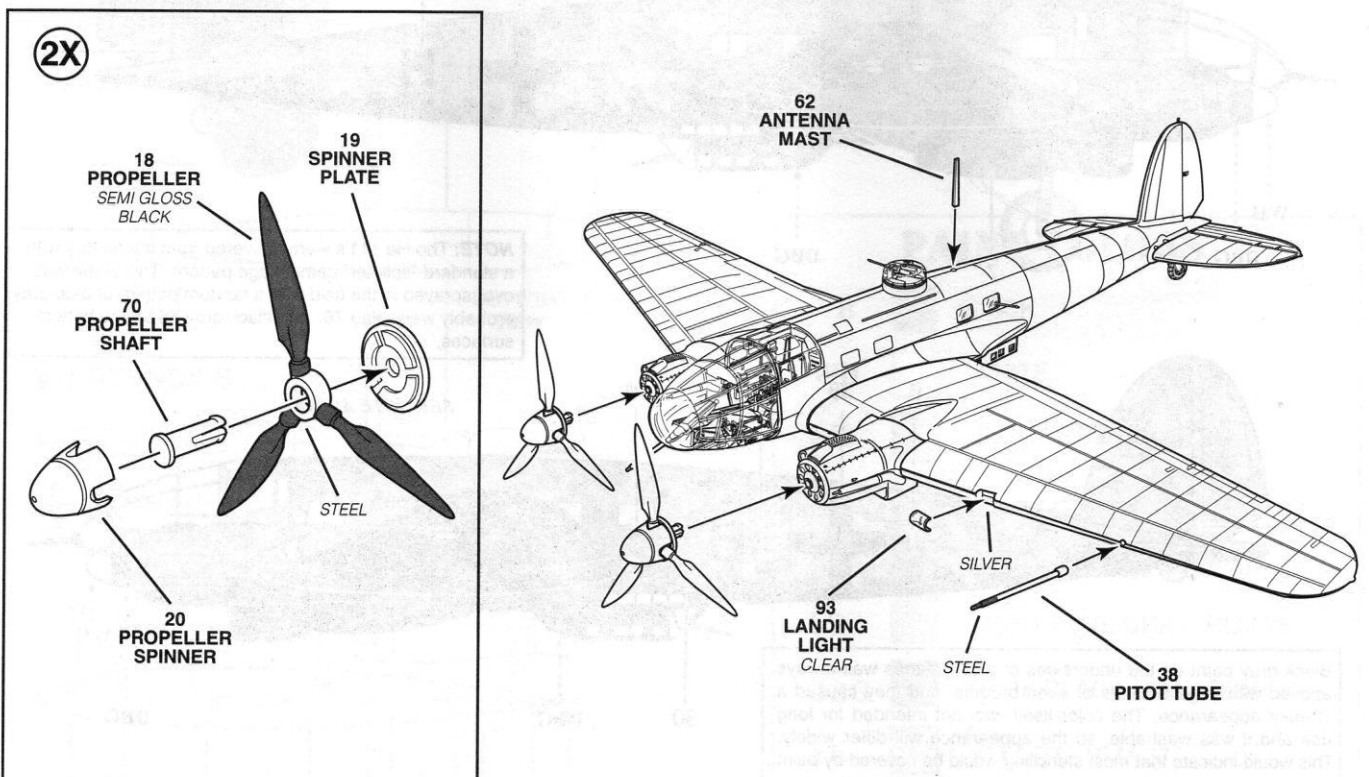

# 17

# DECAL PLACEMENT



## HEINKEL HE 111H-22, 1./KG 53

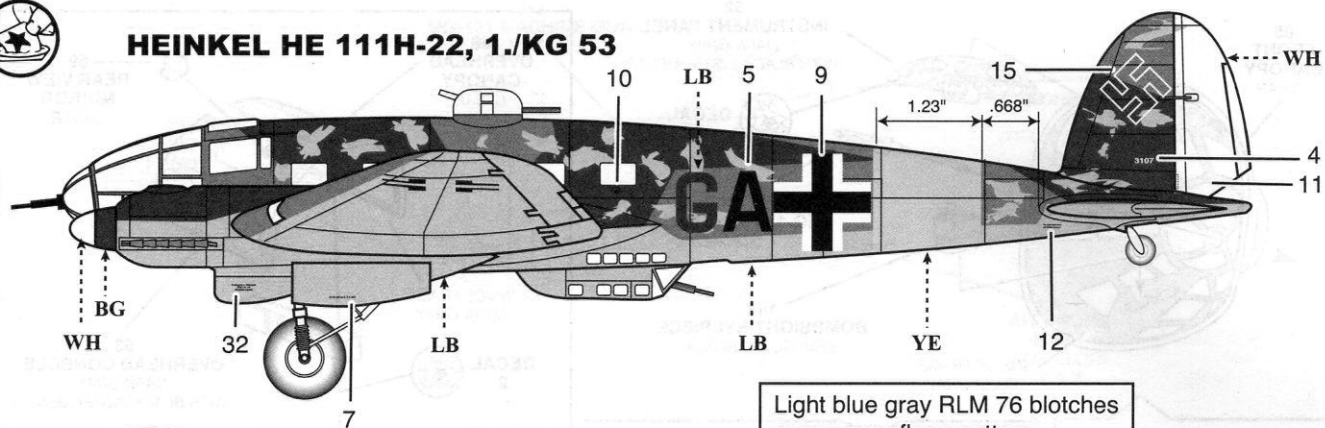

Light blue gray RLM 76 blotches over camouflage pattern.

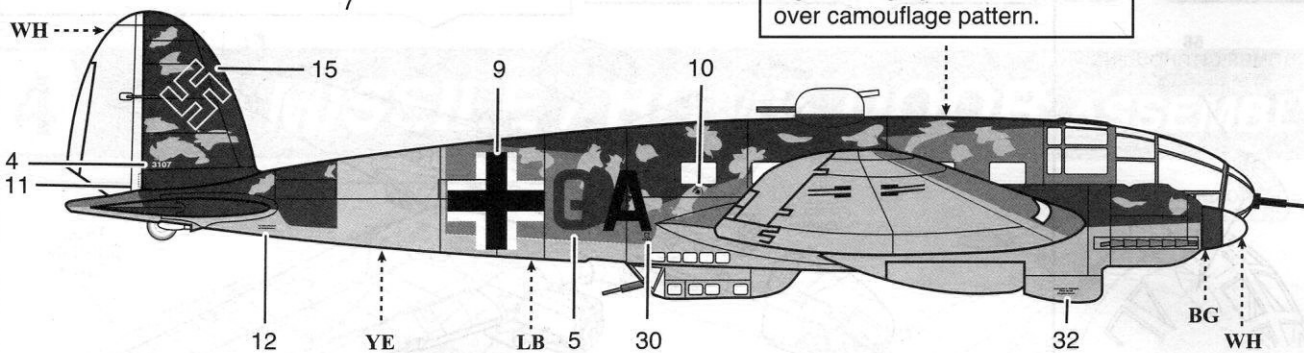

## HEINKEL HE 111H-22, 1./KG 3, VENLO, NETHERLANDS

SEE NOTE BELOW

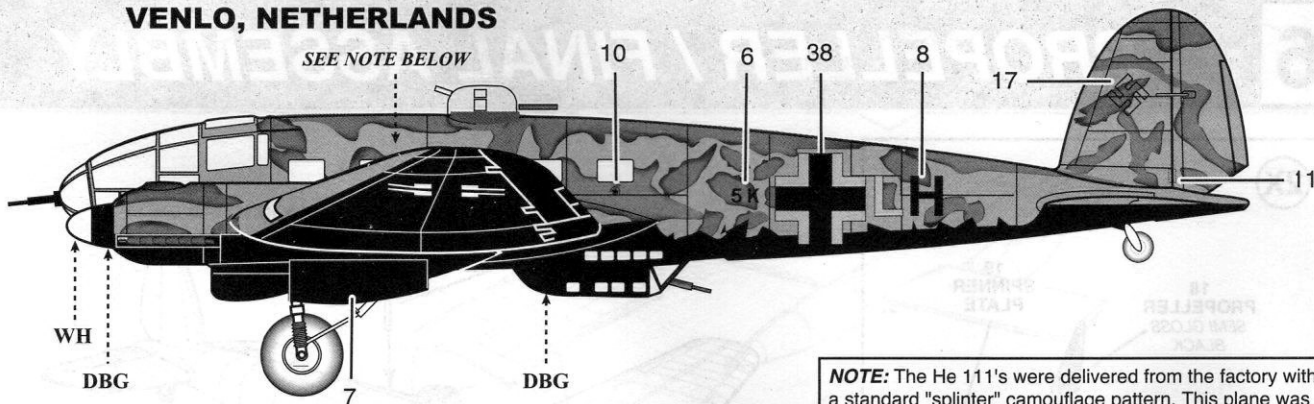

**NOTE:** The He 111's were delivered from the factory with a standard "splinter" camouflage pattern. This plane was over sprayed in the field with a random pattern of blue gray probably weissblau 76, with black gray 66 on the bottom surfaces.

SEE NOTE ABOVE

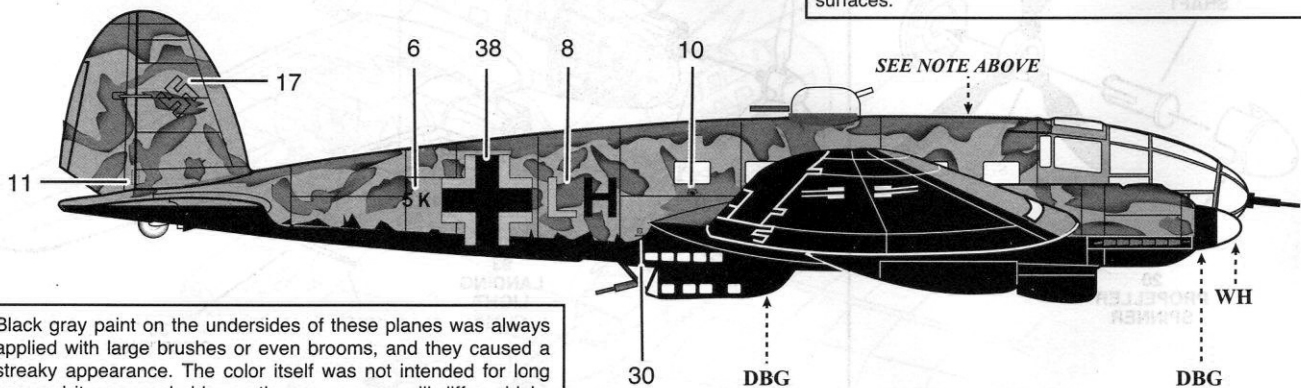

Black gray paint on the undersides of these planes was always applied with large brushes or even brooms, and they caused a streaky appearance. The color itself was not intended for long use and it was washable, so the appearance will differ widely. This would indicate that most stenciling would be covered by paint.

# 18

# DECAL PLACEMENT

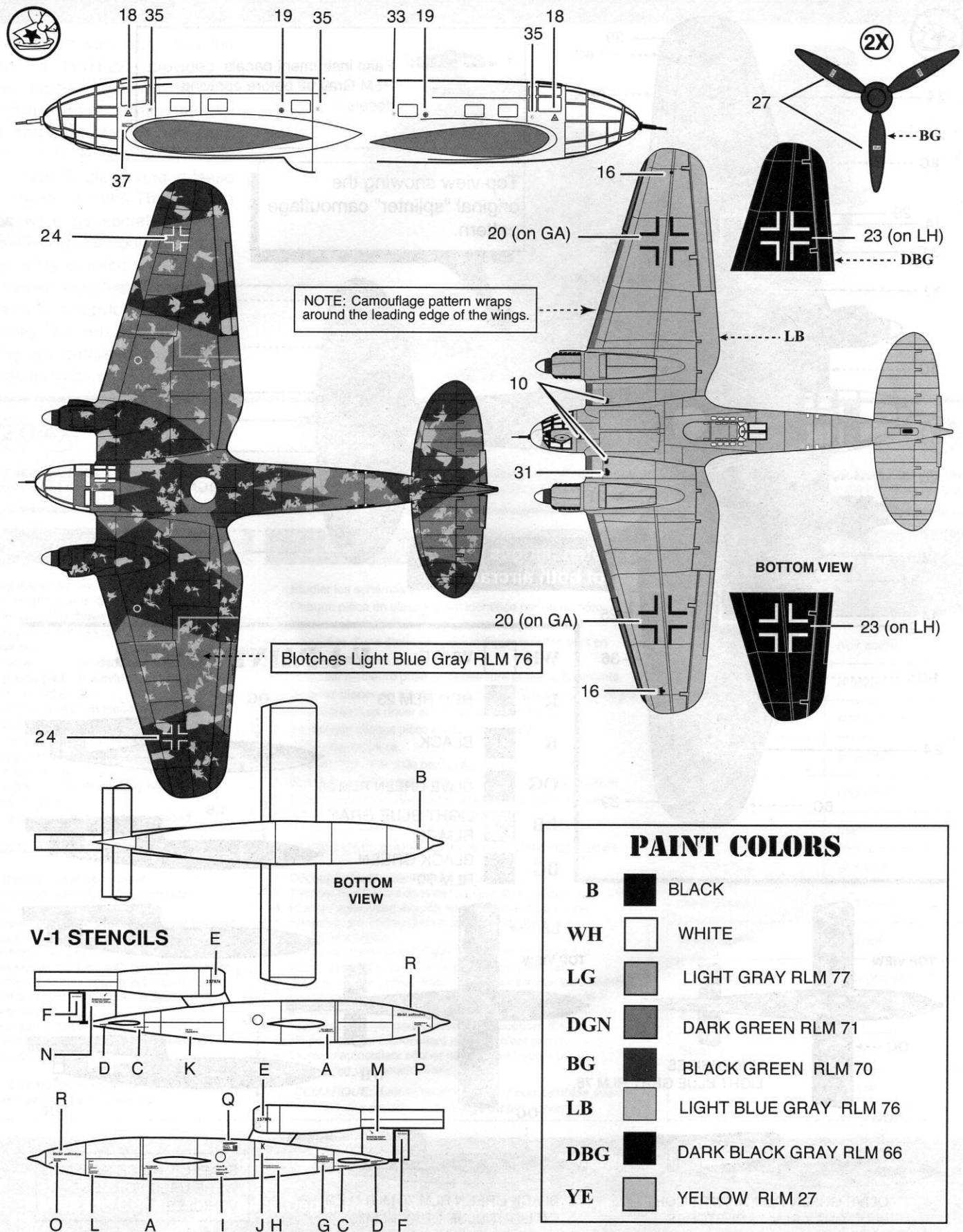

# DECAL PLACEMENT

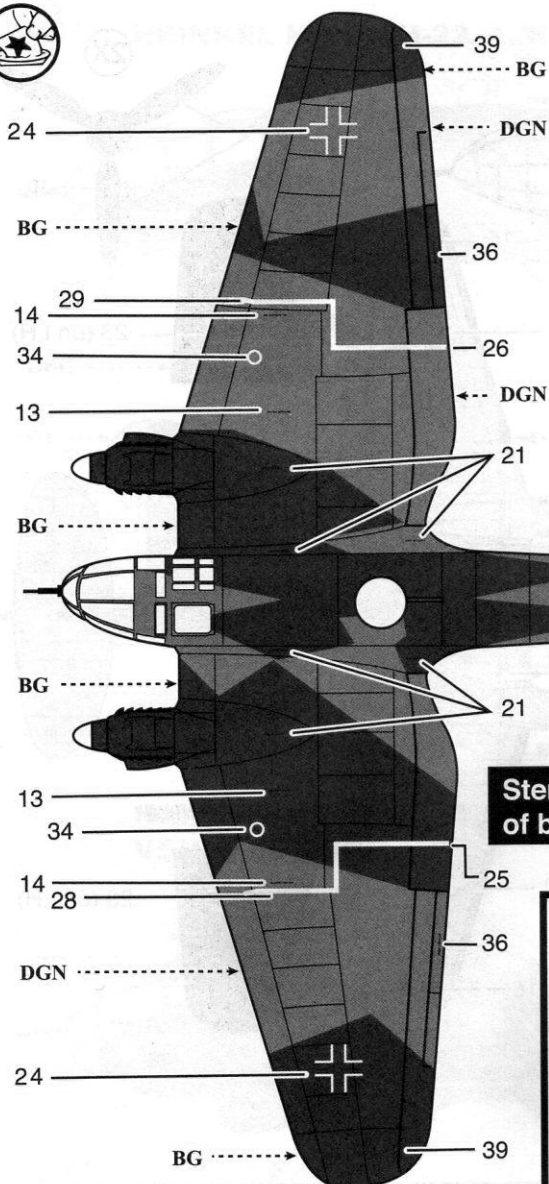

1 Paint instrument panels  
 2 RLM Gray 02 before applying  
 3 decals.

Top view showing the original "splinter" camouflage pattern.

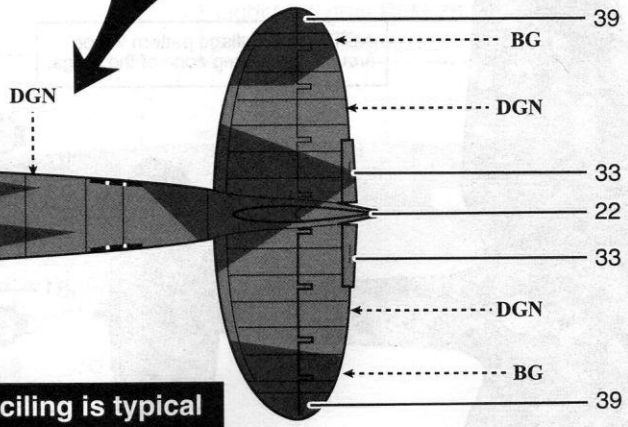

Stenciling is typical of both aircraft.

### V-1 PAINT COLORS

WH		WHITE
R		RED RLM 23
B		BLACK
OG		OLIVE GREEN RLM 28
LB		LIGHT BLUE GRAY RLM 76
BG		BLACK GREEN RLM 70

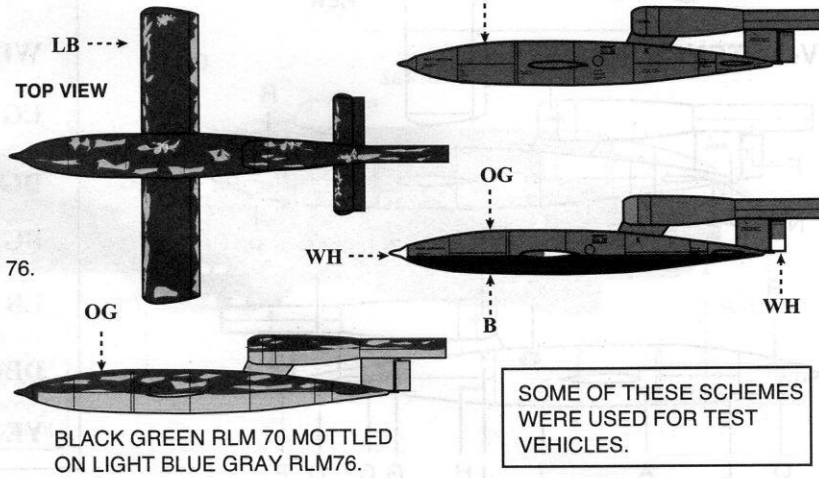
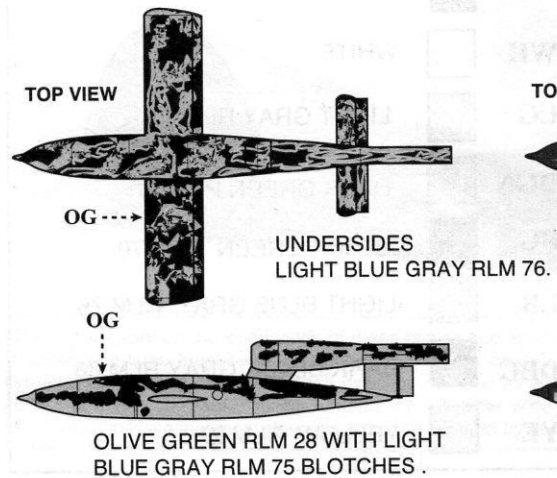
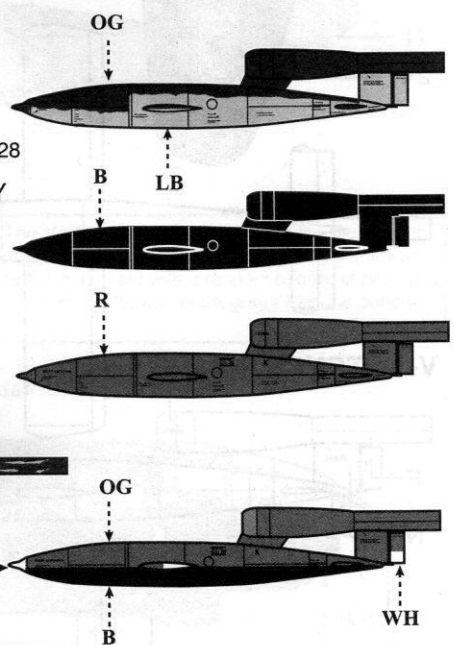

SOME OF THESE SCHEMES WERE USED FOR TEST VEHICLES.